

## ET20 Twin Flood

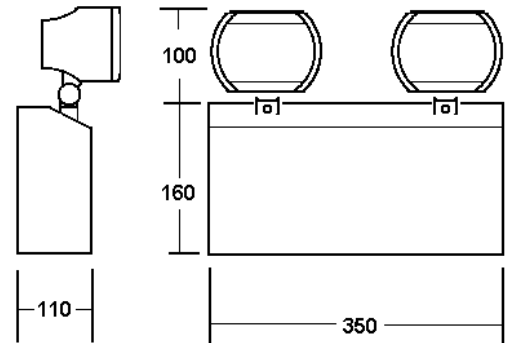

The Premier *ET20* twin projector units provide excellent emergency lighting illuminance for areas requiring high mounting positions. These low cost products utilize twin 20Watt tungsten lamps in adjustable projector heads mounted on a white epoxy coated steel enclosure. The *ET20* twin projector units house 12Volt, five year life Valve Regulated Lead Acid batteries and a high quality charge circuit.

- ▶ Non-maintained 3 hour performance
- ▶ High intensity tungsten projectors
- ▶ Valve Regulated Lead Acid battery
- ▶ Green charge healthy LED indicator
- ▶ 230Volt (220 – 240V) input
- ▶ Designed to comply with EN60598.2.22



Mounting height Hm (m)	Max. between 20W projectors	
	Left	Right
4	22m	24m
6	24m	30m
8	21m	25m
10	-	20m
	1 Lux min. at centre of escape	0.5 Lux min. open area

### ORDER CODES:

**ET20/NM3 Twin 20Watt, Non-maintained, 3 hour duration**

Premier Fire & Safety Systems Limited  
 103 Olympic Way, Fair Oak, Eastleigh, Hampshire, SO50 8QS  
 Tel 07786 564888 Fax 02380 696550 E mail phil@pdkm.demon.co.uk